

- In order to avoid any accidental ingress of solid matter which might damage the internal components of the pump, it is recommended removing the two protection caps placed on the inlet and outlet ports of the pump only immediately before mounting the fittings and the pipework.
- Particular care must be taken when connecting the pump with fittings in order to avoid leaks.
- If a sealing fluid or Teflon® tape is used, do not allow any to enter the pump. It is advisable to use stainless steel or plastic fittings.
- To prevent damage to the pump, do not run it dry.
- Disconnect the power supply before removing the pump.
- Shut down the power supply of the unit when connecting to external control equipment.
- Do not let liquid enter this pump drive.

Warranty

Every new unit manufactured by Fluid-o-Tech is guaranteed to be free of defects in workmanship and material when leaving the factory for a period of 18 months from the production date stamped on the pumps's housing, plus a period of 6 months to cover the warehouse and transit time, or for a period of maximum 24 months from the purchasing date to the first product use. In no event shall this period exceed 24 months from date of original invoice. Fluid-o-Tech will repair or replace at its judgement part or all of the product not conforming to this warranty. Fluid-o-Tech's responsibility under this warranty is limited to the repair or replacement of defective

equipment returned to us on a D.A.P. basis, providing that our analysis discloses that such part or parts were defective at the time of sale.

The warranty is not recognized if:

- The directions on how to handle, install or operate the pump are disregarded.
- The unit has been disassembled or modified by anyone other than a Fluid-o-Tech (or authorized by Fluid-o-Tech) engineer or repaired with non original components.
- The pump operated dry or in cavitation.
- Solid extraneous particles are found in the pump.
- Evident signs of over pressure are observed.
- The pump has been utilized for an application for which it was not intended to be used where the operating conditions and/or the pumped liquid were incompatible with the pump itself and such application has not been specifically approved by Fluid-o-Tech.
- In case of pumps equipped with relief valve, the operating pressure results to be less than 1 bar (14.5 psi) below the relief valve setting. Normal wear and tear is not covered by the present warranty.

The adjustment or replacement of defective parts made under this warranty will not extend the original warranty period.

The Purchaser/User is responsible for the disposal or recycling of the product at end of its use or lifetime. For more information on proper disposal method, please contact Fluid-o-Tech Customer Care.

INSTRUCTION MANUAL

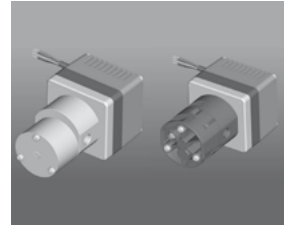

PUMP-MOTOR UNIT FG SERIES

This integrated pump-motor unit is composed by a Fluid-o-Tech mag drive gear pump and a BLDC 24V motor. The units are available in 2 different versions: with or without the integrated electronic driver. Concerning the technical features of the version without

the integrated electronic driver, please refer only to the relevant paragraph "PIN FUNCTION: VERSION WITHOUT ELECTRONIC DRIVER". This version needs that the customer builds a dedicated controller that manages the rotating magnetic field.

OPERATING WORKING CONDITIONS

Nominal torque	100 mNm @ 3500 rpm
Speed range	from 300 to 5000 rpm
Direction of rotation	clockwise / counterclockwise*
Min ambient temperature	5° C/41 F
Max ambient temperature	40° C/104 F at the maximum torque (70° C/158 F at 70 mNm torque)
Max fluid temperature	55° C/131 F at the maximum torque (95° C/203 F at the lower torque)
Unit protection level	IP52 only for the version with electronic driver
Insulation Class	Motor: B, Coils wire: H
Max relative humidity	90% without condense
Storage temperature	- 20° C + 85° C/- 4 F + 185 F

* counterclockwise available only for the version without electronic driver

THE TWO VERSIONS

With integrated electronic driver

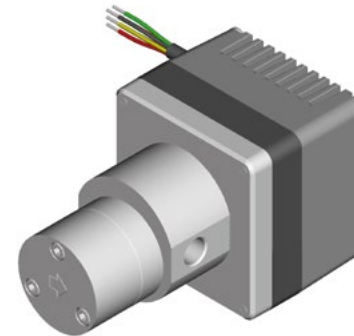

Without integrated electronic driver

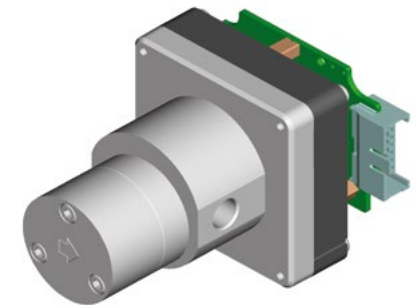

Fluid-o-Tech reserves the right to alter the specifications indicated in this catalogue at any time and without prior notice.

Version with electronic

PIN FUNCTION

WIRE COLOR	SYMBOL	DESCRIPTION	
Red	PWR_VCC	Power supply (+24V)	
Black	PWR_GND	Power ground (0V)	
Orange	SPEED IN	Analog input speed command 0-5V	
		Input voltage	Output (rpm)
		$I_n < 0.2V$	0
		$0.3V < I_n < 5V$	$300 > \text{Out} > 5000$ linearity speed vs command +/- 5% with no load
Brown	0V	0V speed command	
Yellow	TACHO OUT (SPEED OUT*)	DC output voltage: 0-5V DC output source current: max. 5 mA Output square signal frequency: max. 2.7 KHz	
Green	DIRECTION	DC input voltage Vd Vd<2V: clockwise direction (pump side) Vd>4V: counterclockwise direction (pump side)	
IMPORTANT NOTE: NEVER connect PWR GND and 0V together, otherwise the integrated electronic board can be seriously damaged resulting in MOTOR FAILURE <i>* Speed [rpm] = Frequency [Hz] * 60/32 (TTL logic, push-pull driver in serial with a 390 Ω resistor)</i>			

ELECTRICAL CONNECTION

to maintain separated the two 0V reference connections (PWR GND and 0V)

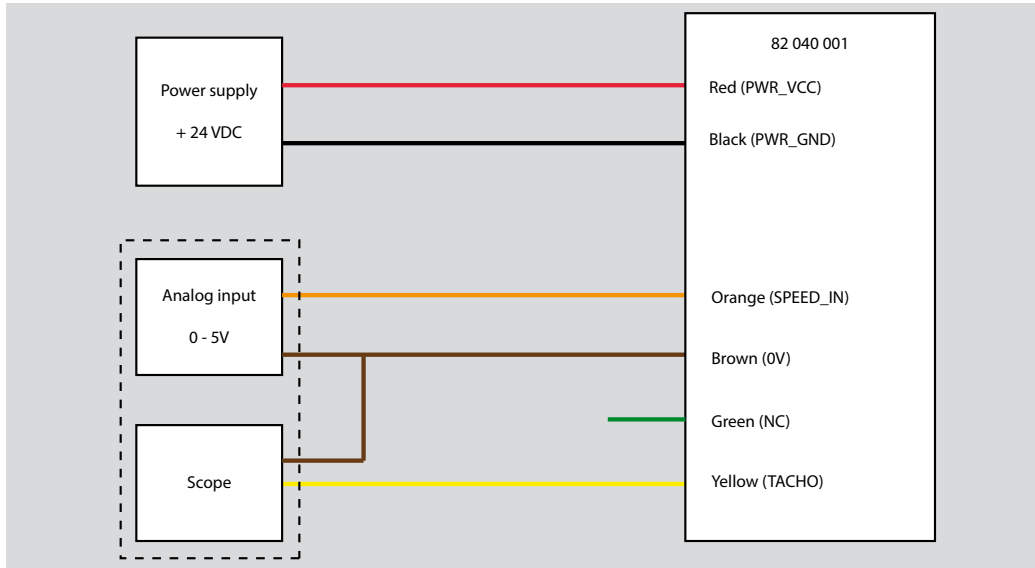

POSSIBLE ALTERNATIVE CONNECTION

NOT connect the 0V speed command (brown) (in this case the speed linearity vs command can be > 5%)

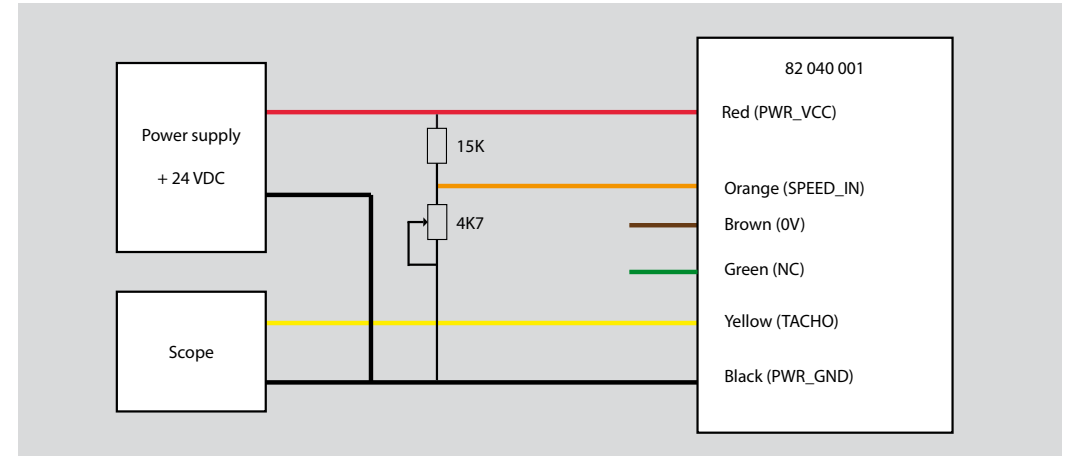

MOTOR FEATURES

ABSOLUTE MAXIMUM RATING					
SYMBOL	PARAMETER	MIN.	TYP. VALUE	MAX.	UNIT
V PWR VCC	Power supply (+24V DC)	-35	24	35	V
I VCC	PWR_VCC current	0	2	4	A
V SPEED_IN	Analog input speed command	-5	5	15	V

FUNCTIONAL RANGE					
SYMBOL	PARAMETER	MIN.	TYP. VALUE	MAX.	UNIT
V PWR VCC	Power supply (+24V DC)	20	24	29	V
I VCC	PWR_VCC current	-	-	3.5	A
SPEED	Speed out	300	-	5000	rpm
TORQUE	Torque out	0	-	100	mNm

DC CHARACTERISTICS AT 24V, AMBIENT TEMPERATURE = 25 °C/77 °F					
SYMBOL	PARAMETER	MIN.	TYP. VALUE	MAX.	UNIT
Rin	Input impedance	-	162	-	K Ω
Voh	High level output voltage	3.8	4.4	-	V
Vol	Low level output voltage	-	0.1	0.44	V
Io	Output current	-	-	20	mA
IVCC	Supply current	-	60	-	mA

Thermal protection

The motor has an internal thermal protection built in the drive board. The thermal upper limit is 120 °C/248 F and when this value is reached the motor is automatically stopped. To restart the system, speed input signal must be set to 0 and the internal temperature must be under 110°C/230 F.

Maximum power & current at 25 °C/77 F ambient and fluid

Under continuous duty (> 30 min of continuous operation) the maximum input power of the unit is 60 Watt (2.5A max) at any speed command. Under intermittent duty (ON-OFF mode) the maximum instantaneous input power of the motor is 84 Watt (3.5A max). This has to be considered the upper limit at any speed command. A lower input power is necessary with:

- air temperature around motor casing >25° C/77 F
- fluid temperature >25° C/77 F
- absence of motor ventilation

We recommend, in the above conditions, performing a thermal transient test on your specific application, layout and duty cycles.

Under/Over voltage protection

The motor has an internal under voltage protection set at 15.5V. When this limit is reached, the motor is automatically stopped. To restart the system the power supply voltage must be over 16.5V and the speed input must be set to 0. The motor has an internal over voltage protection set at 30V. When this limit is reached the

motor is automatically stopped. To restart the system the power supply voltage must be under 29V and the speed input must be set to 0.

Motor stall protection

The motor has a motor stall protection. The motor is automatically stopped if it is not able to rotate for 1 second. To restart the system the speed input must be set to 0.

MOTOR STARTUP AND RESTART PROCEDURES

Initialization time

On the chart below:

- CH1 (Yellow) represent the power supply (0 to 24V)
- CH3 (Purple) represent the time of initialization (0V) to the internal loop of the system (ready to start).

The initialization time of the microcontroller is 65ms.

This time include the time all tension will be OK on the board. The initialization time exist only on "cold start" => supply voltage below than 9V.

Restart procedure

When, a failure is detected (temperature, voltage, stall) a restart procedure is required.

To restart, the physical fault must be corrected:

- Voltage between 16,5V to 29V
- Internal temperature under 90°C
- Rotor free to move.

After that, you have to put the "speed input" to 0V during 10ms to rearm the system.

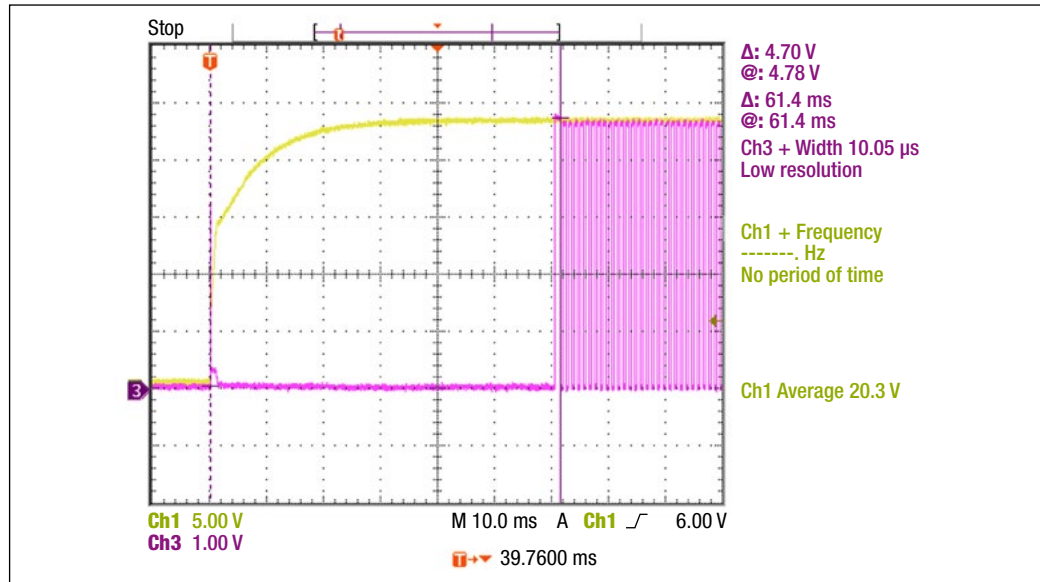

Version without electronic

PIN FUNCTION

MOTOR DRIVING						
HALL			PHASE			WISE
H1	H2	H3	L1	L2	L3	CW
0	1	0		+	-	↓
0	1	1	-	+		
0	0	1	-		+	
1	0	1		-	+	
1	0	0	+	-		
1	1	0	+		-	

8 POLES ROTOR		
REF	CONNECTION*	
1	Hall supply (4.5 - 18V) - Max current: 20mA Output: NPN, open collector	
2	Hall 0V	
3	Output Hall 3	Hall sensors electrical commutation 120 °
4	Output Hall 2	
5	Output Hall 1	
6	Coil 3 R = 0.65 Ω +/- 10%	Nominal voltage: 24V
7	Coil 2 R = 0.65 Ω +/- 10%	Max. voltage: 50V
8	Coil 1 R = 0.65 Ω +/- 10%	Max wire temp.: 120 °C

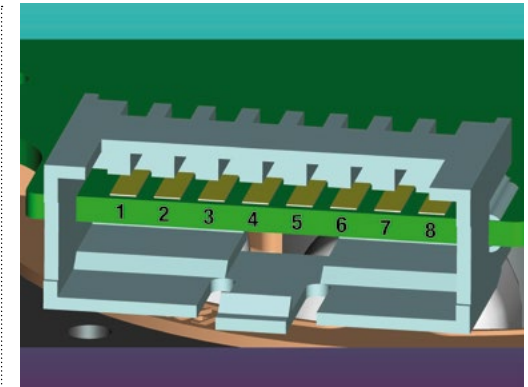

*Board supplied with shell Tyco 8 stripes (1-964575) compatible with connector 2.5 mm 8 positions, Tyco code 1-966194-8 or 3-829868-8

ABSOLUTE MAXIMUM RATING

SYMBOL	PARAMETER	MIN.	MAX.	UNIT
V _{coil}	Voltage applied to the coil (phase)	-50	50	V
I _{coil}	Stator current (phase)	-	5	Arms
V _{DD_Hall} ⁽¹⁾	Hall sensor supply voltage	-	18	V
I _{s_Hall} ⁽¹⁾	Protective power supply current of the Hall sensor	-	50	mA

Attention: Stresses above the max. values listed here may cause permanent damage to the device. Exposure to absolute maximum rating conditions for extended periods may affect device reliability. Maximum ratings are absolute ratings; exceeding only one of these values may cause irreversible damage to the integrated circuit.

⁽¹⁾Data issue of manufacturer.

OPERATING RANGE

SYMBOL	PARAMETER	MIN.	TYP. VALUE	MAX.	UNIT
Vcoil	Voltage applied to the coil (phase)	-50	24	50	V
Icoil	Stator Current	-	3.5 ⁽²⁾	5	Arms
Iterminal ^{(1) (3)}	Connector Terminal Current	-	-	2	Arms
VQ_Hall ⁽¹⁾	Output Voltage Hall	-0.7	-	18	V
IQ_Hall ⁽¹⁾	Output current Hall	0	-	20	mA
Rcoil	Stator phase resistance	0.585	0.65	0.715	Ohm

Notes: ⁽¹⁾ Data issue of manufacturer.

⁽²⁾ Typical value is relative to the nominal working conditions

⁽³⁾ Features in annex of this document.

OPERATING CONDITIONS

Ensure that the pump materials are compatible with the pumped fluid. Fluid-o-Tech pumps are designed to handle clean water at ambient temperature.

Any other fluid and/or operating condition need to be tested and approved by the customer and verified by Fluid-o-Tech. It is strongly recommended, especially for the inlet, using a pipe with an inner diameter sufficient to handle the pump's capacity. This will avoid cavitation and consequent failure of the pump. The discharge pressure must not exceed 12 bar (174 psi) in any event. The piping on the discharge side should therefore be able to handle a pressure of 12 bar (174 psi).

We suggest a 1.5 safety factor. It is also recommended installing a filter before the pump capable of keeping out particles larger than 10 µm which could cause fast wear of the internal components, and with a surface area large enough not to cause hydraulic losses in the circuit. It is also important to check periodically the filter cartridge.

In order to keep the filter under control, it is advisable to install a vacuum gauge after the filter. In case the vacuum increases more than 0.1 bar (1.45 psi), the cartridge should be cleaned or changed. For long pump life, the pumped fluid must not contain any solid particle. Although the magnet drive gear pumps are self-priming, they should operate under wetted conditions, as dry running will cause accelerated wear of the internal components.

A dirty filter or an insufficient inlet supply of water can cause cavitation and accelerated wear of the internal components of the pump. If the suction line is subject

to low pressure or flow, it is recommended fitting a pressure/level switch before the pump in order to switch the motor off when that happens. It is also recommended to protect the system from accidental overpressure with safety devices such as a pressure relief valve or a pressure switch connected to the motor. It is not advisable to install solenoid valves in the circuit; however, if necessary, the solenoid valve should only be installed after the pump. Solenoid valves installed before the pump should be avoided at all times.

The internal diameter of the solenoid valve should be appropriately sized for the pump capacity. In order to avoid pressure spikes the solenoid valve should only be operated after the pump has stopped, allowing a few seconds to go by after the motor has been switched off. If the pump is equipped with a relief valve (bypass), it will act, in case of accidental overpressure, to limit the pressure, by means or recirculating the fluid internally. The relief valve is not a flow regulator, and should not be used as such. If used as a flow regulator, the excess fluid will recirculate within the pump, through the relief valve, and the pump may fail.

The maximum differential pressure should be at least 1 bar (14.5 psi) lower than the relief valve setting in order to avoid fluid recirculation and therefore loss of capacity and ultimately failure. Due to magnetic coupling, the pump does not require a mechanical seal to prevent leakage. This eliminates the usual problems associated with the use of a mechanical seal.

The maximum pressure varies with pump model and speed. As the differential pressure decreases the flow rate will increase.

ASSEMBLING AND DISASSEMBLING THE UNIT TO REPLACE THE PUMP OR THE MOTOR

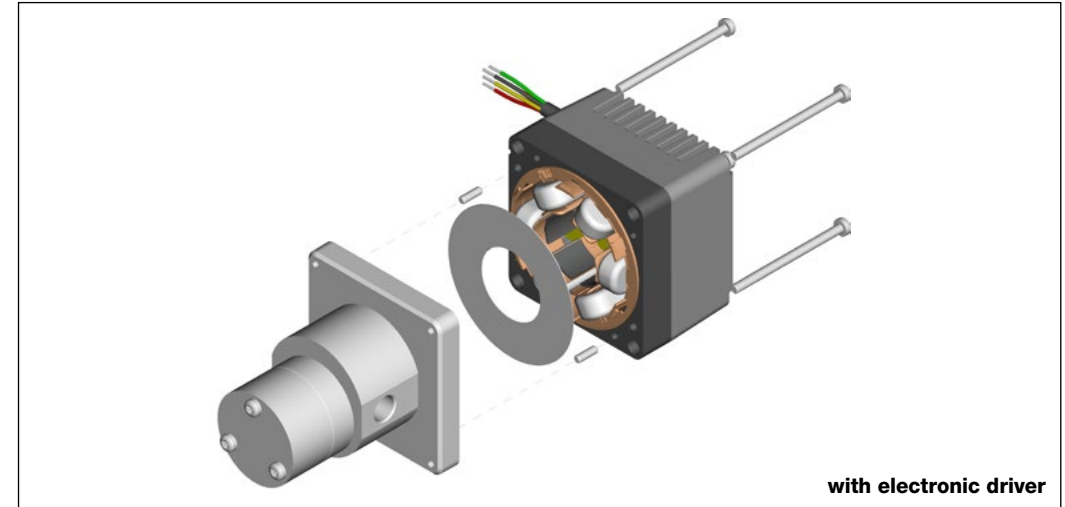

with electronic driver

- 1) Unscrew the 4 screws on the back side of the motor
- 2) Separate motor and pumphead
- 3) Replace the pump or the motor as needed
- 4) Position the plastic ring around the metal magnet cup
- 5) Position the 2 pins inside the 2 holes in the square flange
- 6) Assemble pumphead and motor inserting the 2 pins into the motor holes
- 7) Tighten the 4 screws at 1 Nm +/- 0.2

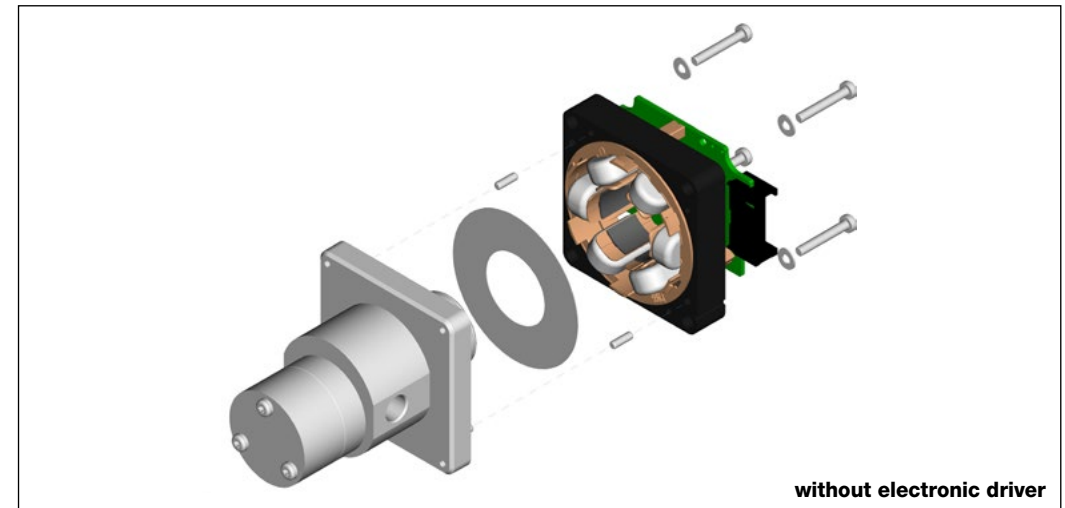

without electronic driver

- 1) Unscrew the 4 screws on the back side of the motor
- 2) Separate motor and pumphead
- 3) Replace the pump or the motor as needed
- 4) Position the plastic ring around the metal magnet cup
- 5) Position the 2 pins inside the 2 holes in the square flange
- 6) Assemble pumphead and motor inserting the 2 pins into the motor holes
- 7) Tighten the 4 screws at 1 Nm +/- 0.2

“C” MOUNTING (94-83-02)

Position the bracket on the stator (12 mm black section) and fix the unit by tighten the 2 feet with 2 M4 screws.

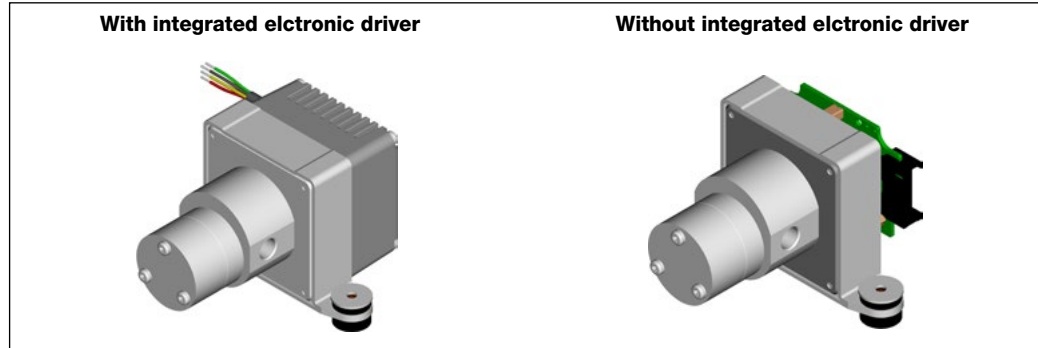

“FRAME” MOUNTING (94-83-01)

Fix the frame on the stator (12 mm black section) with 2 M5 set screws on the 2 sides. Use the 4 holes diameter 5 mm on the frame corners for fixing the unit by M4 screws.

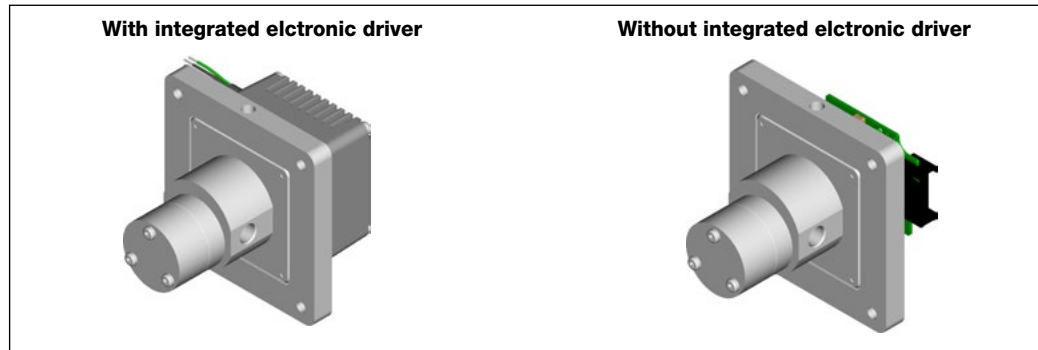

“BULKHEAD” MOUNTING (60-08-02)

The “bulkhead” bracket is integrated with the pump. The o-ring dimensions are Di 69.57 mm T 1.78 mm.

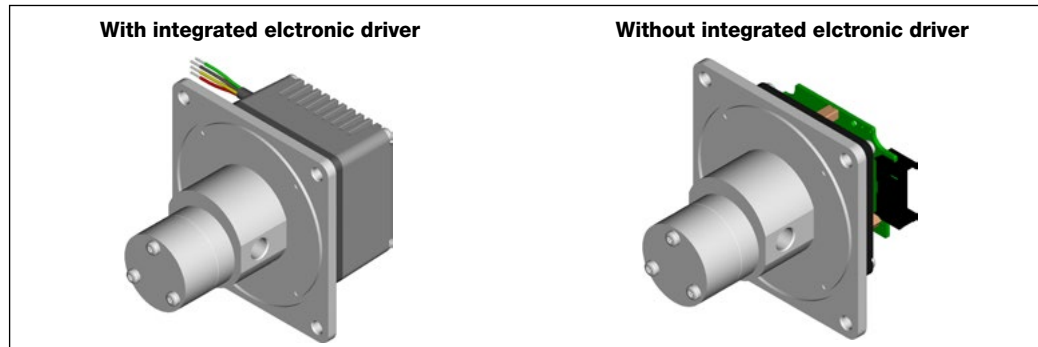

“FOOT” MOUNTING (94-08-04)

Please refer to the paragraph titled “Assembling and disassembling the unit to replace the pump or the motor”. Remember to remove and replace the screws with M3x50 in steel class A2-70 ones.

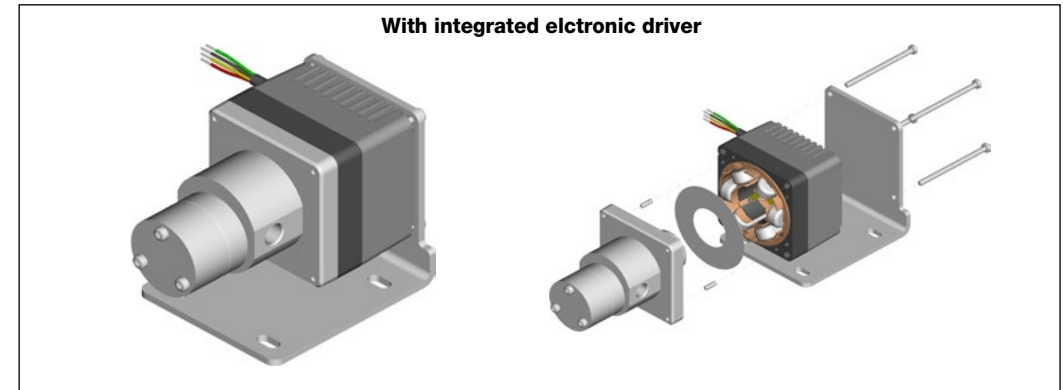

CERTIFICATION

NSF listed FG units available for drinkable liquids. For the model details, please refer to the official NSF website (direct link available on www.fluidotech.it) Pump/Motor units are considered a part of machine, and therefore supplied with the “CE” mark, and will satisfy the requirements of the following Directives:

- Directive 2014/30/ EU of the European Parliament and of the Council, of 26th February 2014, related to the Electromagnetic Compatibility – EMC.
- Directive 2014/35/ EU of the European Parliament and of the Council, of 26th February 2014, related to the electric material intended to be used within specified voltage limits – DBT, for those groups whose supply voltage is greater than 75V, or the Directive 2006/42/ CE, related to the Machinery, for those groups whose

supply voltage is lower than 75V.

- Directive 2014/34/ EU of the European Parliament and of the Council, of 26th February 2014, related to equipments and protection devices intended to be used in potentially explosive environments - ATEX.
- Directive 2011/65/ EU of the European Parliament and of the Council, of 08 June 2011, and Delegated Directive 2015/863 of the Uropean Commission of 31st March 2015, on the restriction of the use of certain hazardous substances in electrical and electronic equipment – RoHS.

A Fluid-o-Tech Declaration of Conformity can be requested to state compliance with the above Directives.

**The versions without the integrated electronic driver are certified only NSF and CE*



Important information:

Please read the operating manual carefully before using the unit.



Warnings

- For food and medical applications the pump (even when NSF listed) needs to be sanitized by circulating water at 80 °C/176 F for at least 20 minutes. Water used for this operation must not be reused, either during the sterilization or later, but must be discharged.

- The magnetic coupling does not guarantee a defined value of the discharge pressure. Should it be necessary to protect the hydraulic circuit from any possible fluid hammers generated by the pump, it is vital using a pump, equipped with a bypass or a safety valve to be installed after the pump itself.
- NEVER connect PWR GND and 0V together, otherwise the integrated electronic board can be seriously damaged resulting in MOTOR FAILURE.